



AVM70LH

QUICK START GUIDE

Multimedia Receiver with Bluetooth and DualMirror featuring a 6.2" digital TFT LCD

This Quick Start Guide gives you the basics to start using your AVM70LH. Please visit www.axxeraaudio.com/support/manuals.php to download a complete owner's manual or call customer service at 1-866-382-5476 (Monday-Friday, 9AM-5PM EST).



Customer Service Toll Free: 1-866-382-5476

Safety Notes:
The DVD video display of the in-dash unit will not operate while the vehicle is moving. This is a safety feature to prevent driver distraction. In-dash DVD video functions will only operate when vehicle is in Park and the parking brake is engaged. It is illegal in most states for the driver to view video while the vehicle is in motion.

Installation

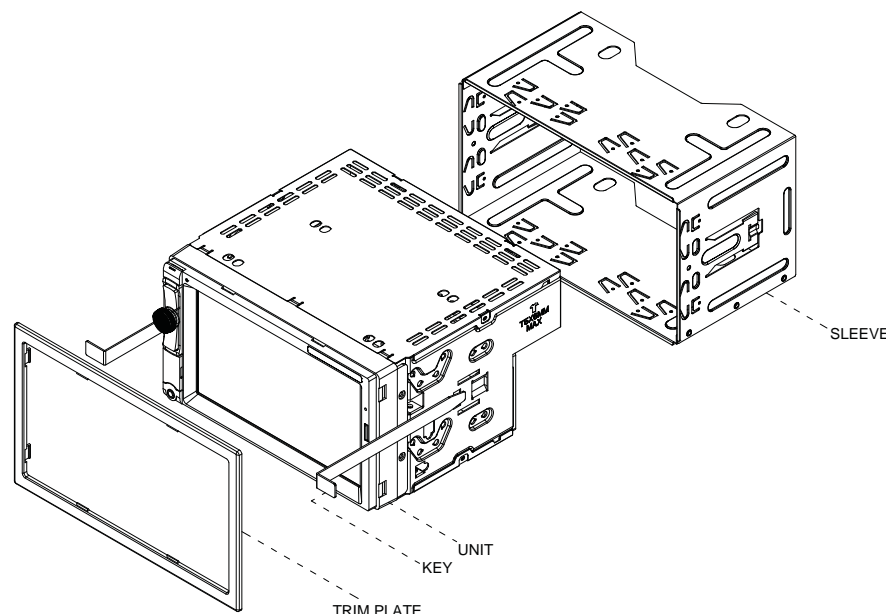

TYPICAL FRONT-LOAD DIN MOUNTING METHOD

Copyright and Trademark Notes
This product incorporates copyright protection technology that is protected by method claims of certain U.S. patents and other intellectual property rights owned by Macrovision Corporation and other rights owners. Use of this copyright protection technology must be authorized by Macrovision Corporation, and is intended for home and other limited viewing uses only unless otherwise authorized by Macrovision Corporation. Reverse engineering or disassembly is prohibited. DVD Logo is a trademark of DVD Format/Logo Licensing Corporation registered in the U.S., Japan and other countries. SD Logo is a trademark of SD-3C, LLC. iPod and iPhone are trademarks of Apple Inc., registered in the U.S. and other countries. Dual Electronics Corporation is not affiliated with Apple, Inc. Other trademarks and trade names are those of their respective owners.

Wiring Diagram - Inputs/Outputs

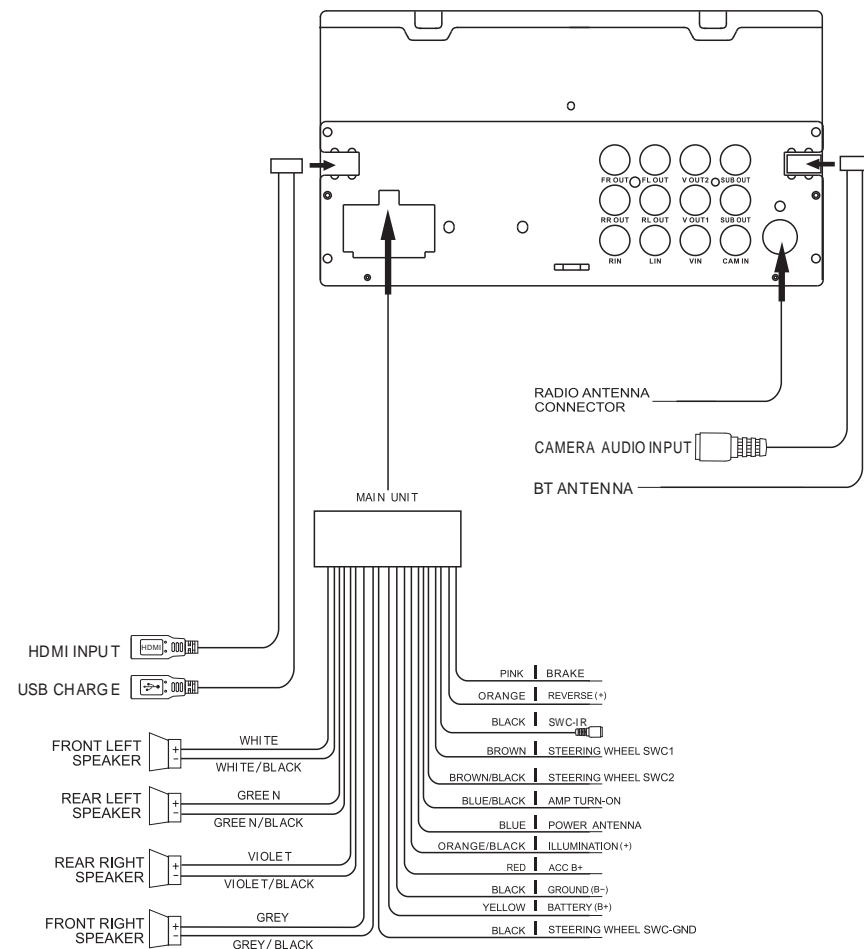

Control Locations



- | | |
|-----------------|----------------------|
| 1. microSD Card | 6. Tune/Track Up |
| 2. Mic | 7. Power/Volume/Mute |
| 3. IR Sensor | 8. Tune/Track Down |
| 4. Reset | 9. USB Slot |
| 5. Mode | 10. AUX Input |

Remote Control

- | | |
|------------------------|------------------------------|
| 1. Power | 15. Audio |
| 2. Mode | 16. * |
| 3. Play/Pause | 17. Loud |
| 4. Mute | 18. Number keys |
| 5. Talk | 19. Root |
| 6. End call | 20. OSD (On Screen Display) |
| 7. Setup | 21. Local/Random |
| 8. Goto | 22. Seek Down/Previous Track |
| 9. Home | 23. AS/PS/Repeat |
| 10. Volume UP | 24. Stereo |
| 11. Zoom | 25. Stop |
| 12. Select | 26. Enter |
| 13. Seek UP/Next Track | 27. Band |
| 14. Volume Down | |

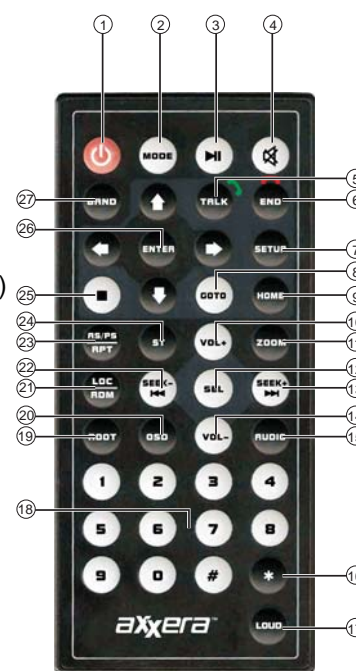

Main Menu

In the Menu mode, press the desired icon to enter the corresponding mode: Tuner, DualMirror, USB, SD Card, BT Phone, BT Music, Camera, Aux In, AV In, Setup.



Tuner Operation

Select the Tuner icon from the Main Menu screen or press MODE unit Tuner is selected.

1. Current Mode Indicator
2. Information Display
3. Tune Up
4. Preset
5. AS/PS
6. Stereo
7. Local/DX
8. Band
9. Tune Down



General Operation

Press the function icons to select in setup menu.



Audio Operation

Press Sound Effect icon In setup menu to select Preset, 7-band tone control, Surround, Fader and Balance.

1. EQ Setting
2. Surround Setting
3. Fader/Balance



Screen Operation

In setup menu press one of RGB to adjust the screen condition.



Bluetooth Operation

Bluetooth Microphone
The microphone is built-in to the receiver.

Pairing and Connecting
Before you can use a Bluetooth device, it must be paired and connected. The Multi Media broadcasts the pairing signal constantly when no devices are currently connected. Complete the pairing sequence from your Bluetooth device. The device name is "Axxera AVM70LH". The Bluetooth passcode "0000". Once pairing is complete, most Bluetooth will connect automatically if the device is in range when the unit is powered-on.

Dialing a Number
Press **BTPhone** to display keypad and dial a number.

Making and Ending a Call
Press **BTPhone** to connect a call, and press **BTPhone** to end a call.

Transferring Audio
Press **BTMusic** to transfer audio between the head unit and mobile phone.

Streaming Audio
Press **BTMusic** to play or pause the music. Press **BTMusic** to skip to the previous track. Press **BTMusic** to advance to the next track.



DualMirror™ Operation

See insert for DualMirror Operation Guide.

Note:
Operating system updates from Apple and Android may cause issues with your receiver not to function properly. This can usually be fixed by doing a software/firmware update to the receiver itself. To see if your receiver has the latest firmware, contact customer service at 1-866-382-5476 to see if your radio needs an update.



One-Year Limited Warranty

This warranty gives you specific legal rights. You may also have other rights which vary from state to state. Dual Electronics Corp. warrants this product to the original purchaser to be free from defects in material and workmanship for a period of one year from the date of the original purchase. Dual Electronics Corp. agrees, at our option, during the warranty period, to repair any defect in material or workmanship or to furnish an equal new, renewed or comparable product (whichever is deemed necessary) in exchange without charges, subject to verification of the defect or malfunction and proof of the date of purchase. Subsequent replacement products are warranted for the balance of the original warranty period. Who is covered? This warranty is extended to the original retail purchaser for products purchased from an authorized Dual dealer and used in the U.S.A. What is covered? This warranty covers all defects in material and workmanship in this product. The following are not covered: software, installation/removal costs, damage resulting from accident, misuse, abuse, neglect, product modification, improper installation, incorrect line voltage, unauthorized repair or failure to follow instructions supplied with the product, or damage occurring during return shipment of the product. Specific license conditions and copyright notices for the software can be found via www.dualav.com.

What to do?
1. Before you call for service, check the troubleshooting guide in your owner's manual. A slight adjustment of any custom controls may save you a service call.
2. If you require service during the warranty period, you must carefully pack the product (preferably in the original package) and ship it by prepaid transportation with a copy of the original receipt from the retailer to an authorized service center.
3. Please describe your problem in writing and include your name, a return UPS shipping address (P.O. Box not acceptable), and a daytime phone number with your shipment.
4. For more information and for the location of the nearest authorized service center please contact us by one of the following methods:
• Call us toll-free at 1-866-382-5476 (Monday-Friday, 9:00 a.m. to 5:00 p.m. EST)
• E-mail us at cs@dualav.com
Exclusion of Certain Damages: This warranty is exclusive and in lieu of any and all other warranties, expressed or implied, including without limitation the implied warranties of merchantability and fitness for a particular purpose and any obligation, liability, right, claim or remedy in contract or tort, whether or not arising from the company's negligence, actual or imputed. No person or representative is authorized to assume for the company any other liability in connection with the sale of this product. In no event shall the company be liable for indirect, incidental or consequential damages.

FCC Compliance

This device complies with Part 15 of the FCC Rules. Operation is subject to the following two conditions:
(1) this device may not cause harmful interference, and
(2) this device must accept any interference received, including interference that may cause undesired operation.
Warning: Changes or modifications to this unit not expressly approved by the party responsible for compliance could void the user's authority to operate the equipment.
Note: This equipment has been tested and found to comply with the limits for a Class B digital device, pursuant to Part 15 of the FCC Rules. These limits are designed to provide reasonable protection against harmful interference in a residential installation. This equipment generates, uses and can radiate radio frequency energy and, if not installed and used in accordance with the instructions, may cause harmful interference to radio communications. However, there is no guarantee that interference will not occur in a particular installation. If this equipment does cause harmful interference to radio or television reception, which can be determined by turning the equipment off and on, the user is encouraged to try to correct the interference by one or more of the following measures:
• Reorient or relocate the receiving antenna.
• Increase the separation between the equipment and receiver.
• Connect the equipment into an outlet on a circuit different from that to which the receiver is connected.
• Consult the dealer or an experienced radio/TV technician for help.